

BLUETOOTH ENABLED

DAVEY ProMaster®

VSD200



INNOVATIVE
POOL PUMP
NOW WITH BLUETOOTH®

APPLICATION

Ideal for pool filtration, in-floor pool cleaning systems, connection to external pool controllers, heat pumps and gas heaters. Suitable for pools up to 110,000 litres.



Smartphone control via
DAVEY Pool Pump App



HIGH EFFICIENCY, SUPER QUIET, WATER COOLED DESIGN

- > **Bluetooth** enabled to allow set and control functionality from your iOS or Android smartphone.
- > **Super Quiet** – Designed with a unique water cooled motor which captures noise and vibrations, allowing super quiet operation, rated down to 50dBa. Your neighbours won't even know it's there.
- > **Full Variable Speed Control** – The ProMaster offers the pool owner and operator total control over the speed at which the pump needs to operate, from 1,500rpm to 3,600rpm
- > **Energy Efficiency** – 8 Star energy rating offering up to 70% lower energy use than a traditional fixed speed 1hp pump*
- > **Backwash Function** – ProMaster is designed with a selectable backwash cycle that runs the pump for 2 minutes at 3,800rpm before shutting down, providing reliable and easy operation of the pump when backwashing your media filter.
- > **Dependable** – ProMaster incorporates unique loss of prime protection to minimise pump damage if no water is available to the pump.
- > **Convenient** – By water cooling the motor, ProMaster does not require air ventilation, and gives installers more flexibility with pump positioning
 - Easy to install set and operate, no complicated digital push button controls
 - Automatic restart technology
 - Large 4.5 litre leaf basket for long intervals between cleaning
- > **Double insulated to water circuit** – provided with an Equipotential Bonding Point for AS/NZ 3000 wiring standards

*Running your pump at low speed uses less energy to turnover the same amount of pool water.



Depend on Davey

DAVEY

ProMaster Bluetooth® VSD200 Pool Pump

Bluetooth smartphone control via IOS or Android app 

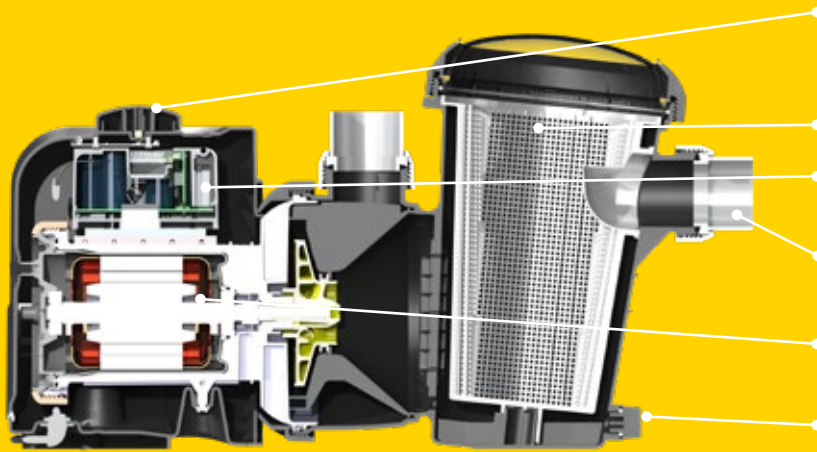

- Variable Frequency Drive** with selectable speed dial from 1500rpm to 3600rpm (Backwash mode at 3800rpm)
- Large Leaf Basket** with easy to remove, clear lid
- Loss of prime protection** to protect the pump when there is no water inside the pump
- Quality ABS quick coupling barrel unions** for simple installation
- High performance water cooled motor** for super quiet, efficient use all year round
- Drain plug** enables quick draining of the casing for easy removal and maintenance

ELECTRICAL DATA

| | |
|--------------------------|--|
| Voltage (V) | 240 |
| Supply frequency (Hz) | 50 |
| Motor input power (W/hp) | 116W/0.16hp @ Dial 1 488W/0.65hp @ Dial 5 1,000W/1.34hp @ Dial 10 1316W/1.76hp @ Backwash |
| Motor speed (rpm) | 1,500 to 3,600 |
| Backwash (rpm) | Variable |
| Enclosure class (IP) | 45 |
| Insulation class | F |
| Power lead length | 3m |
| Approval No. | SGS-150025-EA |

| OPERATING LIMITS | Max. water temperature | Max. ambient temperature | Noise level (AS 5102.2) |
|------------------|------------------------|--------------------------|-------------------------|
| | 40°C | 50°C | 50 dBa (at Speed 1) |

HYDRAULIC PERFORMANCE

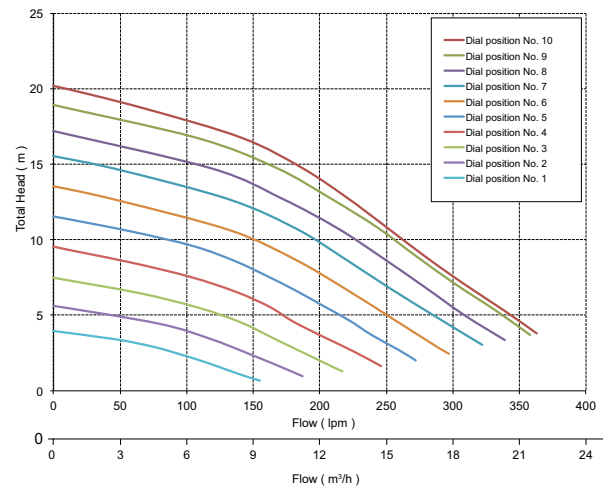

DIMENSIONS (mm)

| Model | A | B | C | D | E | F | G | H | I | Mounting Holes Diameter | Inlet/Outlet PVC | Net Weight (kg) |
|---------|-----|-----|-----|-----|----|-----|-----|-----|-----|-------------------------|------------------|-----------------|
| PM200BT | 305 | 670 | 320 | 350 | 65 | 230 | 380 | 200 | 250 | 10 | 40/50 | 14 |

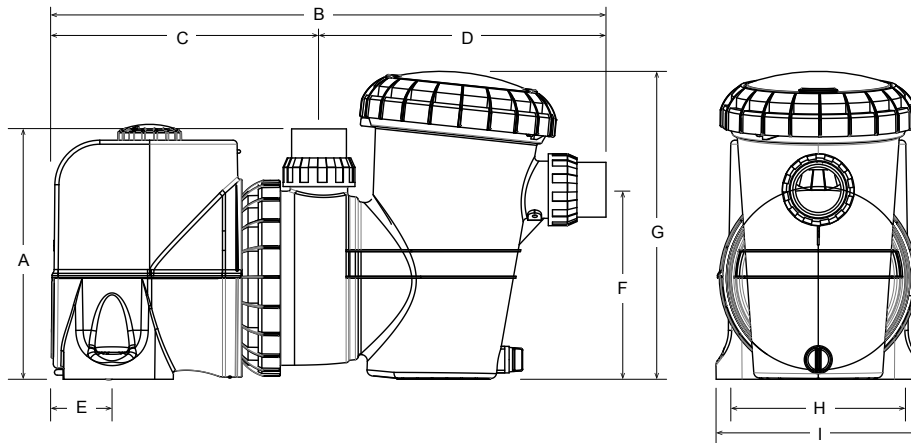

davey.com.au | daveynz.co.nz | daveyeurope.eu | daveyusa.com

This literature is not a complete guide to product usage. All images provided in this document are for illustration purposes only. Further information is available from your Davey Dealer, Davey Support Centre and from the relevant product Installation and Operating Instructions. Must be read in conjunction with the relevant product Installation and Operating Instructions and all applicable statutory requirements. Product specifications may change without notice. © Davey is a registered trademark of Davey Water Products Pty Ltd. © Davey Water Products Pty Ltd 2018.

DAVEY